

DS11

Plastic Variable Area Flowmeter for low Flow Rates with Glass Measuring Tube

- for low viscous liquids and gases
- fittings made of PVDF
- with integrated needle valve
- limit switches optional
- accuracy class 2,5
- max. pressure 4 bar
max. temperature 100 °C
- measuring ranges: 0,25...160 l/h water
0,5...5000 NI/h air



Description:

The flowmeters DS11 operate according to the proven variable area principle. The flowing media moves a float upwards against gravity in a conical measuring tube. The height of the float indicates the flow rate and may be read off a burnt-in scale on the measuring tube.

Optional inductive contacts, which are mounted on the measuring tube, may be used for flow rate limit detection. All meters are equipped with an integrated needle valve for exactly regulating the flow rate.

Typical applications:

Variable area flowmeters model DS10 are mainly used for measuring and monitoring the flow rate of low- viscous liquid and gaseous media.

Scales for water or air at standard operating conditions have already been defined. For other media or different process conditions special scales are available.

Measuring ranges: (Standard Scales)

Float made of stainless steel

The measuring ranges given below serve as orientation. Please indicate medium, pressure and temperature, we will calculate an individual scale for you.

Measuring range No	Measuring range [Nl/h] air, 20°C, 1,2 bar abs.	Contact version
01	0,5...5	A
02	0,8...8	A
03	1,6...16	A
04	4...40	A
05	6...60	A
06	10...100	B
07	25...250	B
08	50...500	B
09	80...800	B
10	100...1000	B
11	180...1800	B
12	240...2400	B
13	300...3000	B (min)
14A	400...4000	B (min)
15A	500...5000	B (min)
[l/h] water		
16	0,25...2,5	A
17	0,5...5	B
18	1,2...12	B
19	2,5...25	B
20	4...40	B
21	6...60	B
22	10...100	B (min)
23	12...120	B (min)
24	16...160	B (min)

Contacts: The contact version is determined by the measuring range.

(min) = Contact available for minimum monitoring only.

Dimensions:

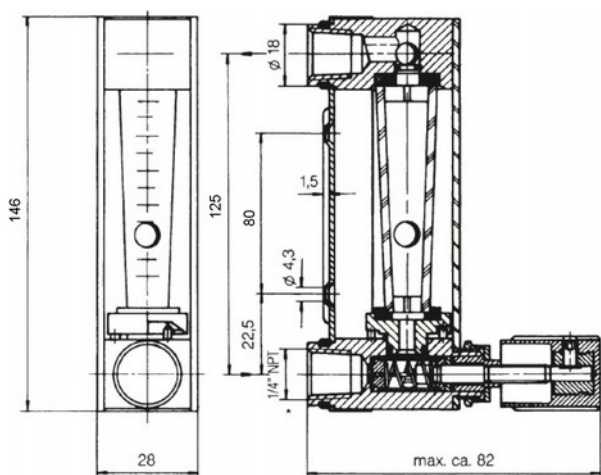

The upper edge of the float is the reading edge.

Order Code:

Order number: **DS11. 2. 1. P. 1. 06. 1. 1. 0.**

Plastic variable area flowmeter with glass measuring tube

Model:

2 = Standard version

Process connection:

1 = G 1/4 female on back
2 = 1/4" NPT on back

Material:

P = PVDF

Gasket:

1 = PTFE/FPM (standard)
2 = PTFE / FFKM
3 = EPDM

Measuring ranges:

01...24 = according to table
99 = special ranges

Valve:

0 = without
1 = valve at inlet (standard)
2 = valve at outlet

Limit switches:

0 = without
1 = 1 contact (model A)
2 = 2 contacts (model A)
3 = 1 contact (model B)
4 = 2 contacts (model B)

Options (multiple answers possible):

0 = without
1 = panel mounting kit
2 = cable connector housing for devices with contact

Special connections like hose connectors, SWAGELOK, ERMETO or others on request.

To operate the limit switches, switch amplifiers of type P+F are required. See data sheet **P+F**.

Technical Data:

Max. pressure: 4 bar

Max. medium temperature: 100 °C (65 °C with contact)

Accuracy: 2,5 % of measured value

Materials:

fitting: PVDF

measuring tube: borosilicate glass

float: st. st. 1.4401, optional glass, POM, Titan, Hastelloy® C4, polypropylene

valve: st. st. 1.4571, 1.4404
optional: PEEK

gaskets: PTFE / FPM,
optional: PTFE / FFKM, PTFE / EPDM

protective cap: polycarbonate

Switching contact: acc. to NAMUR (bistable)

1 mA passage from top to bottom

3 mA passage from bottom to top