

DS10

Variable Area Flowmeter with Glass Measuring Tube

- for low viscous liquids and gases
- fittings of brass or stainless steel
- with integrated needle valve
- limit switch optionally
- accuracy class 4, 2,5 or 1,0
- max. pressure 10 bar, max. temperature 100 °C
- measuring ranges: 0,04...160 l/h water
0,5...5000 NI/h air



Description:

The flowmeters DS10 operate according to the proven variable area principle. The flowing media moves a float upwards against gravity in a conical measuring tube. The height of the float indicates the flow rate and may be read off a burnt-in scale on the measuring tube.

Optional inductive contacts, which are mounted on the measuring tube, may be used for flow rate limit detection. All meters are equipped with an integrated needle valve for exactly regulating the flow rate.

Typical applications:

Variable area flowmeters model DS10 are mainly used for measuring and monitoring the flow rate of low- viscous liquid and gaseous media.

Scales for water or air at standard operating conditions have already been defined. For other media or different process conditions special scales are available.

Models:

- DS10.1:** miniature version, installation high 111 mm
accuracy class 4
- DS10.2:** standard version, installation high 146 mm
accuracy class 2,5
- DS10.3:** maxi version, installation high 196 mm
accuracy class 2,5
- DS10.4:** precision version, installation high 346 mm
accuracy class 1,0

Measuring Ranges:

The measuring ranges given below serve as orientation. Please indicate medium, pressure and temperature, we will calculate an individual scale for you.

Measuring range- No	Measuring range [NI/h] air, 20°C, 1,2 bar abs.	Contact- version	Models			
			DS10.1	DS10.2	DS10.3	DS10.4
01	0,5...5	A	x	x	-	-
02	0,8...8	A	x	x	-	-
03	1,6...16	A	x	x	x	x
04	4...40	A	x	x	x	x
05	6...60	A	x	x	x	x
06	10...100	B	x	x	x	x
07	25...250	B	x	x	x	x
08	50...500	B	x	x	x	x
09	80...800	B	x	x	x	x
09A	120...1200	B	x	-	-	x
10	100...1000	B	-	x	-	x
11	180...1800	B	-	x	-	x
12	240...2400	B	-	x	-	x
13	300...3000	B (min)	-	x	-	x
14A	400...4000	B (min)	-	x	-	-
15A	500...5000	B (min)	-	x	-	-
[l/h] water						
40A	0,04...0,4	-	-	-	-	x
41A	0,063...0,63	-	-	-	-	x
42A	0,1...1	-	-	-	-	x
43A	0,16...1,6	A	-	-	-	x
16	0,25...2,5	A	x	x	-	x
17	0,5...5	B	x	x	x	x
18	1,2...12	B	x	x	x	x
19	2,5...25	B	x	x	x	x
20	4...40	B	x	x	x	x
21	6...60	B	x	x	x	x
22	10...100	B (min)	x	x	x	x
23	12...120	B (min)	x	x	-	-
24	16...160	B (min)	x	x	-	-

x = available - = not available

Contacts: The contact version is determined by the measuring range.

(min) = Contact available for minimum monitoring only.

Dimensions:

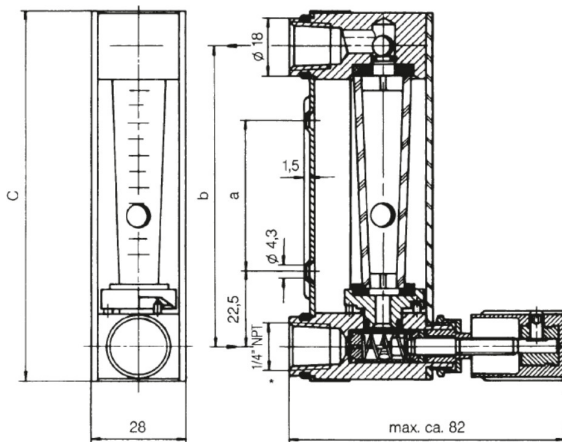

The upper edge of the float is the reading edge.

Models	a [mm]	b [mm]	c [mm]
DS10.1	45	90	111
DS10.2	80	125	146
DS10.3	130	175	196
DS10.4	280	325	346

Order Code:

Order number: **DS10. 2. 1. 1. 06. 1. 1. 0**

**Variable area flowmeter
with glass measuring tube**

Models:

- 1 = miniature version
2 = standard version
3 = maxi version
4 = precision version

Process connection:

- 1 = G 1/4 female on back
2 = 1/4" NPT on back

Material:

- 1 = brass
2 = stainless steel

Gasket:

- 1 = FKM (standard)
2 = PTFE / FFKM
3 = EPDM

Measuring ranges:

- 01...24 = according to table
99 = special ranges

Valve:

- 0 = without
1 = valve at inlet (standard)
2 = valve at outlet

Limit switches:

- 0 = without
1 = 1 contact (contact model A)
2 = 2 contacts (contact model A)
3 = 1 contact (contact model B)
4 = 2 contacts (contact model B)

Options (multiple answers possible):

- 0 = without
1 = panel mounting kit
2 = cable connector housing for devices with contact

Special connections like hose connectors, SWAGELOK, ERMETO or others on request.

To operate the limit switches, switch amplifiers of type P+F are required. See data sheet **P+F**.

Technical Data:

Max. pressure: 10 bar

Max. medium temperature: 100 °C (65 °C with contact)

Materials:

- fitting and valve:** brass or stainless steel,
float: stainless steel
gaskets: FKM / EPDM or PTFE / FFKM,
measuring tube: borosilicate glass

Accuracy:

- DS10.1: class 4
DS10.2: class 2,5
DS10.3: class 2,5
DS10.4: class 1,0

Switch contacts:

- acc. to NAMUR (bistable)
1 mA passage from top to bottom
3 mA passage from bottom to top