

SERIES 54000

Spring Loaded Emergency Pressure Vent

SERIES 54000



- Sizes 16" (DN 400) through 24" (DN 600)
- Vents directly to atmosphere
- Pressure setting achieved by spring loading
- Suitable for use on higher working pressure tanks
- Provides emergency relief in the event of external fire
- Factory tested / certified for leakage and correct settings
- Available in Carbon Steel and Stainless Steel

OBJECTIVE

Protectoseal Series 54000 Spring Loaded Emergency Pressure Vents provide emergency pressure relief for storage tanks as well as access for tank cleaning, inspection and repair work. They are designed for installation on the manhole opening of the tank and provide a means of relieving large volumes of vapors, beyond the capacity of a normal operating vent, if an emergency fire involvement of the tank should occur. Series 54000 Emergency Pressure Vents do not provide vacuum relief. Vacuum relief must be supplied by operating vents such as Protectoseal Series 830, 8540, 6240, 16240 and 18540.

TECHNIQUE

Even tanks with high design ratings require protection from excessive pressure accumulation in their vapor space. With the set pressures allowed by a spring loaded design, the vent can remain closed at higher pressures and is allowed to open only when the tank structure may be in jeopardy. Vapors can then be relieved to maintain the tank within its design parameters.

The set point is determined by combined spring force and weight of components acting upon the mean seat diameter of the vent. Settings are adjustable within a specified range for any spring combination, by increasing or decreasing compression of springs.

SPECIAL FEATURES

Fast Inspection, Easy Maintenance. Diaphragm may be replaced by removal of springs and pallet assembly from the vent.

Maintains Accurate Pressure Settings. Set points are accurate to within +/- 3% across the entire range of available pressure relief settings shown in the chart on the reverse. Set point accuracy is assured by stringent machining, assembly and test procedures.

Wide Range of Set Points. Series 54000 Spring-Loaded Emergency Vents can be set at 1 PSIG or higher. Refer to setting chart on reverse for setting ranges.

Sizes Available. Available in 16" (DN 400) through 24" (DN 600) sizes. Flanged to mate with standard flanged 150# ANSI, API (20" or 24" only) or DIN PN 16 bolting specifications. Other drilling patterns are also available upon special request.

PRO-FLOW® Sizing and Selection Software.

Use PRO-FLOW® Sizing and Selection Software to select the correct size unit for emergency pressure relief calculated in accordance with API 2000, ISO 28300, NFPA 30 and OSHA 1910.106.

Quality Assurance. Each vent is factory tested for correct setting and leakage to meet Protectoseal's high standards prior to shipment.

CONSTRUCTION

A comprehensive range of materials is offered as shown in the chart below.

Available Options.

- Alternate diaphragm materials
- Material certifications for flange and seat
- FEP coating
- Kynar® coating (*Kynar® is a Registered Trademark of Arkema, Inc.*)

Series	Base Flange/Seat	Hood	Spring Package	Diaphragm
AXC54000	Steel/316 S.S.	Steel	S.S.	Viton®
AXF54000	316 S.S.	316 S.S.	S.S.	Viton®

Viton® is a registered Trademark of E.I. DuPont de Nemours & Co., Inc.

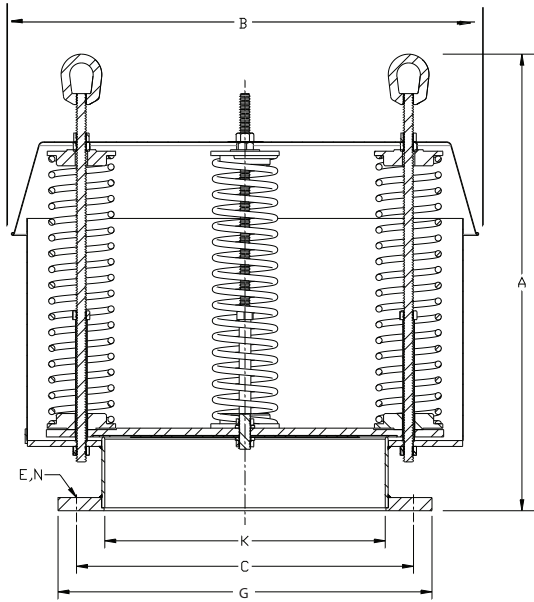

Dimensions shown are for reference only, contact Factory for certified drawings.

DIMENSIONS & ORDERING INFORMATION

Cat. No.*	Flange Size	I.D. K	Ht. A	Width B	Dia. G	B.C. C	Dia. E	Holes N
54016ASA	16"	15 1/4"	30"	31 3/4"	23 1/2"	21 1/4"	1 1/8"	16
54016DN	DN 400	410mm	762mm	806mm	580mm	525mm	30mm	16
54018ASA	18"	15 1/4"	30"	31 3/4"	25"	22 3/4"	1 1/4"	16
54018DN	DN 450	462mm	762mm	806mm	640mm	578mm	30mm	20
54020ASA	20"	20 1/2"	30 1/2"	39 7/8"	27 1/2"	25"	1 1/4"	20
54020API	20"	20 1/2"	30 1/2"	39 7/8"	26"	23 1/2"	3/4"	16
54020DN	DN 500	513mm	773mm	1013mm	715mm	650mm	33mm	20
54024ASA	24"	24"	39"	40"	32"	29 1/2"	1 3/8"	20
54024API	24"	24"	39"	40"	30"	27 1/2"	3/4"	20
54024DN	DN 600	616mm	991mm	1016mm	840mm	770mm	36mm	20

* Refer to Setting Chart to complete part number.

Add Prefix	Base Flange/Seat	Hood	Spring Package	Diaphragm
AXC	Steel/316 S.S.	Steel	S.S.	Viton®
AXF	316 S.S.	316 S.S.	S.S.	Viton®

Viton® is a registered Trademark of E.I. DuPont de Nemours & Co., Inc.

PRESSURE AND/OR VACUUM SETTINGS (Consult factory for settings outside of STANDARD range.)

Flange Size	Minimum Setting	STANDARD MINIMUM & MAXIMUM SETTINGS		Maximum Setting
		Range - "A" Suffix Standard Setting	Range - "B" Suffix Standard Setting	
16"/DN 400	1 PSIG	1 PSIG up to 5 PSIG	5 PSIG up to 11 PSIG	11 PSIG
18"/DN 450	1 PSIG	1 PSIG up to 5 PSIG	5 PSIG up to 11 PSIG	11 PSIG
20"/DN 500	1 PSIG	1 PSIG up to 2.3 PSIG	2.3 PSIG up to 7 PSIG	7 PSIG
24"/DN 600	1 PSIG	1 PSIG up to 3.75 PSIG	3.75 PSIG up to 5 PSIG	5 PSIG

ADDITIONAL PRODUCTS FROM PROTECTOSEAL

Series 18540



Pipe-Away Pressure Vacuum Relief Vent for applications that require hazardous vapors be processed into manifolded piping and not released into the atmosphere.

Series 7800



Emergency Vent protects tanks against rupture or explosion resulting from excessive internal pressure caused by exposure to fires.

Series 4950



Vent Line / In-Line Parallel Plate Flame Arrester is designed for installation in open vent pipe or bleed lines from storage or processing tanks. Suitable for NEC Group D (IEC Group IIA) vapors.

Series 830



Combination Pressure / Vacuum Relief Vent & Flame Arrester provides pressure and vacuum relief as well as protection from propagation of externally introduced flames. Suitable for NEC Group D (IEC Group IIA) vapors.